

Hydraulic Casing Gas Compressor – 15 hp Gas Drive Trailer

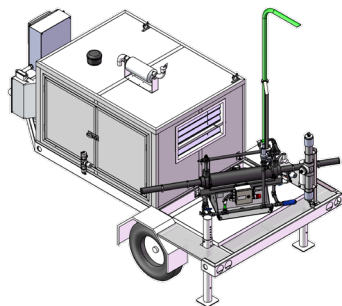

KEY FEATURES

- Capable of handling liquids and slugs
- Maximum ΔP up to 2410 kPa (350 psi)
- 100% turndown capability
- Small footprint
- Engine drive for sites with no electric power
- Highly portable for testing well response
- NHSP (No Hassle Service Plan) & SkyView

COMPRESSOR

Type	Hydraulic drive low speed reciprocating compressor	
Capacity Control	Automatic by PLC, 100% turndown	
Wiring	Class 1 Div 2 Hazardous location	
Piping	SA-106B Threaded spools	
Max Discharge Pressure	1100 psi std / 1500 optional	7600 / 10,300 kPa
Max Design Discharge Temperature	400°F	200°C
Max ΔP (616 Cylinder)	350 psi	2410 kPa
Max Geometric Displacement	30 mcf/d	857 m³/day

HYDRAULIC POWER PACK

Driver	4-cylinder natural gas drive engine	
Usable power	44 hp @ 2400 rpm	
Fuel Consumption	422 scf/hr / 287 m³/d	
Ignition	Electronic	
Starter	Electric	
Oil Conditioning	Slipstream 10 micron filter	
Oil Capacity	8.6 gal / 33 L	
Silencer	Mac – whisper quiet	
Governor	Woodward electronic	
Hydraulic Pump	External gear pump	
Hydraulic Oil Filter	6 Micron	
Hydraulic Oil Capacity	34 gal / 129 L	
Hydraulic Cooling	Offline cooling loop, bar and plate cooler, fan-cooled	
Hydraulic Oil Temperature Control	Automatic: warm-up, cold-start protection	
Wiring	General purpose (remote from compressor)	

CONTROLS AND INSTRUMENTATION

System Control	PLC with data logging
Readout	Multifunction LCD display
Engine Analog Gauges	Oil pressure, coolant temperature, fuel pressure
Web Enabled Remote Monitoring	Satellite callout for operating conditions, Alarms, Shutdowns

WEIGHTS AND DIMENSIONS

Trailer Weight	5450 lb / 2472 kg	
Trailer Dimensions	181" L x 86" W x 96" H / 460 cm x 218 cm x 244 cm	
Inlet Connector	1" NPT	Hose available
Discharge Connector	1" NPT	Hose available

ALARMS AND SHUTDOWNS

	Alarm	Shutdown
Suction Pressure Low	✓	
Discharge Pressure High	✓	
Differential Pressure High	✓	
Discharge Temperature High	✓	
Hydraulic Oil Temperature Low	✓	
Hydraulic Oil Temperature High	✓	
Hydraulic Oil Leak	✓	
Hydraulic Oil Level Low	✓	
Engine Oil Level Low	✓	
Engine Coolant Temperature High		✓
Engine Oil Pressure Low		✓
ESD		✓

OPTIONS

- High discharge pressure transmitter
- Piping for corrosive process gas
- Hydraulic heat trace

APPLICATIONS

- Casing Gas Compression (Sweet & Sour Service)
- Tank Vapour Recovery
- Flaring / Venting Reduction
- Gas Recovery From Treaters/Separators
- Pressure Boosting
- Pigging / Pig Launching
- SAGD / CSS Production Optimization
- Compressor Seal Vapour Recovery
- Frac Flowback Gas Recovery

© 2002-2021 Compact Compression, Inc.

sales@compactcompression.com
<https://www.compactcompression.com>



#8, 1820 – 30th Avenue NE, Calgary, AB T2E 7M5
 Telephone: (403) 219-3026 Fax: (403) 717-1759

FLEXIBLE • RELIABLE • ECONOMICAL • PORTABLE • OPERATOR FRIENDLY



HCG15T

PERFORMANCE

* Projected performance based on elevation 2500 ft, gas density .665, temperature 68°F - Flow rates in mscfd e³m³/day

Hydraulic Casing Gas Compressor – 15 hp Gas Drive Trailer

HCG15 Gas Engine Trailer with 616 Cylinder															
DISCHARGE PRESSURE Max ΔP: 350 psi / 2410 kPa															
SUCTION PRESSURE	PSI	100	125	150	175	200	225	250	275	300	325	350	375	400	
	kPa	700	860	1035	1205	1380	1550	1725	1900	2070	2240	2410	2590	2760	
	5	32	32	32	32	32	28	28	28	28	28	25			
	35	0.9	0.9	0.9	0.9	0.9	0.8	0.8	0.8	0.8	0.8	0.7			
	10	42	42	42	42	39	39	39	39	35	35	35			
	70	1.2	1.2	1.2	1.2	1.1	1.1	1.1	1.1	1.0	1.0	1.0			
	15	53	53	53	49	49	49	49	46	46	46	46			
	105	1.5	1.5	1.5	1.4	1.4	1.4	1.4	1.3	1.3	1.3	1.3			
	20	63	63	60	63	63	60	56	56	56	56	53			
	140	1.8	1.8	1.7	1.8	1.8	1.7	1.6	1.6	1.6	1.6	1.5			
	30	81	81	81	81	77	77	77	77	74	74	74			
	210	2.3	2.3	2.3	2.3	2.2	2.2	2.2	2.2	2.1	2.1	2.1			
	40	102	102	98	98	98	98	95	95	95	95	91			
	275	2.9	2.9	2.8	2.8	2.8	2.8	2.7	2.7	2.7	2.7	2.6			
	50	123	119	119	119	116	116	116	116	112	112	112	112	109	
345	3.5	3.4	3.4	3.4	3.3	3.3	3.3	3.3	3.2	3.2	3.2	3.2	3.1		
75	172	168	168	168	165	165	165	161	161	161	158	158	158		
520	4.9	4.8	4.8	4.8	4.7	4.7	4.7	4.6	4.6	4.6	4.5	4.5	4.5		
100		217	217	217	214	214	214	210	210	210	207	207	207		
700		6.2	6.2	6.2	6.1	6.1	6.1	6.0	6.0	6.0	5.9	5.9	5.9		
125			266	266	263	263	259	259	259	256	256	256	252		
860			7.6	7.6	7.5	7.5	7.4	7.4	7.4	7.3	7.3	7.3	7.2		
150				315	312	312	308	308	308	305	305	305	301		
1035				9.0	8.9	8.9	8.8	8.8	8.8	8.7	8.7	8.7	8.6		
175					364	361	361	357	357	354	354	354	350		
1205					10.4	10.3	10.3	10.2	10.2	10.1	10.1	10.1	10.0		
200						410	410	406	406	403	403	403	399		
1380						11.7	11.7	11.6	11.6	11.5	11.5	11.5	11.4		

© 2002-2021 Compact Compression Inc.

sales@compactcompression.com
<https://www.compactcompression.com>



#8, 1820 – 30th Avenue NE, Calgary, AB T2E 7M5
 Telephone: (403) 219-3026 Fax: (403) 717-1759

FLEXIBLE • RELIABLE • ECONOMICAL • PORTABLE • OPERATOR FRIENDLY

